

INDIVIDUAL PIT MODULE

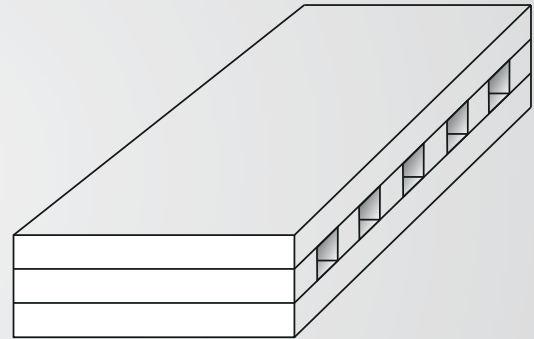

- 18 oz woven polyester and breather
- Core is made from polyurethane foam (lattice system)
- Latex free, lead free, phthalate free, mildew and rot resistant, UV resistant
- 2 year warranty on manufacturer defect
- Made in Canada

COATED VINYL FABRIC (PVC)

1. California Bill 1108 compliant meeting less than 0.1 % phthalates
2. Lead free test ASTM 1613
3. FR to NFPA 701 USA /CPAI 84 Section (2 second extinguish)
4. Fire Retardant to CAN/ULCS 109
5. Fire Retardant to ASTM E84 Class A

SPECIAL FEATURES

- Overall Weight 18 oz per square yard
- Mildew and rot resistant
- Ultraviolet light resistant
- Weave count 20/20
- Tensile 444/441
- Adhesion 17 lbs /2"
- Tongue tear 81 x 83 lbs/inch
- Low cold crack -40 degrees Celsius
- **VELCRO® Brand fasteners**

THREAD

Anfeil Nylon Bonded Tex 90(M30)

FOAM SPECIFICATIONS

- Polyurethane foam, open cell, 1.2 lbs./cubic ft., 20 I.F.D (Indentation Force Deflection)
- Foam meets California Technical Bulletin 117 for Smolder flammability test
- Foam passes Standard Smolder Resistance of resilient filling material test (Technical Bulletin 117 2013)
- Federal Motor Vehicle Safety Std. 302