

# 1" OR 2" SINGLE PANEL EXERCISE MAT 2' X 4', 5' OR 6' WITH HANDLE

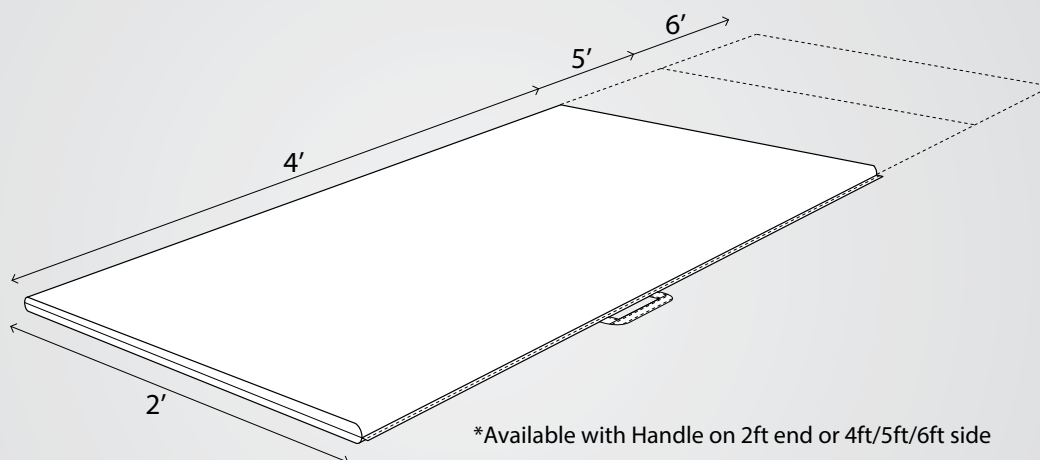

**apple**  
ATHLETIC PRODUCTS



\*Available with Handle on 2ft end or 4ft/5ft/6ft side



- Universal exercise mat for stretching and light impact exercise
- Single panel mat
- Dimensions available:  
2' x 4' x 1" / 2' x 5' x 1" / 2' x 6' x 1"  
2' x 4' x 2" / 2' x 5' x 2" / 2' x 6' x 2"
- Available with handle on 2ft end or 4ft/5ft/6ft side
- 18 oz woven polyester
- Core is made from 1" or 2" polyurethane foam (polyethylene upon request)
- Latex free, lead free, phthalate free, mildew and rot resistant, UV resistant
- 2 year warranty on manufacturer defect
- Made in Canada

## COATED VINYL FABRIC (PVC)

### AVAILABLE COLOURS

Cobalt Royal Blue, Royal Blue 2, Navy Blue, Forest Green, Kelly Green, Red, Burgundy, Purple, Pink, Yellow, Orange, White, Grey, Tan, Brown, Black

1. California Bill 1108 compliant meeting less than 0.1% phthalates
2. Lead free test ASTM 1613
3. FR to NFPA 701 USA/CPAI 84 Section (2 second extinguish)
4. Fire Retardant to CAN/ULCS 109
5. Fire Retardant to ASTM E84 Class A

### SPECIAL FEATURES

- Overall Weight 18 oz per square yard
- Weave count 20/20
- Tensile 444/441
- Adhesion 17 lbs/2"
- Tongue tear 81 x 83 lbs/inch
- Low cold crack -40 degrees Celsius

## FOAM SPECIFICATIONS

- 1" thick polyurethane foam, open cell, 2.0 lbs/cubic ft., 100 I.F.D (Indentation Force Deflection)
- Foam meets California Technical Bulletin 117 for Smolder flammability test
- Foam passes Standard Smolder Resistance of resilient filling material test (Technical Bulletin 117 2013)
- Federal Motor Vehicle Safety Std. 302 Pass

### THREAD

Anefil Nylon Bonded Tex 90 (M30)

Apple Athletic Products (1995) Inc. | [www.appleathletic.com](http://www.appleathletic.com) | [info@appleathletic.com](mailto:info@appleathletic.com)

Toll: 1.800.461.8952 | Tel: 705.325.6455 | Fax: 705.325.8695 | P.O. Box 2265, 256 Hughes Road, Orillia, ON L3V 6S1