

2.5" SAFEGUARD APPLE WALL PAD

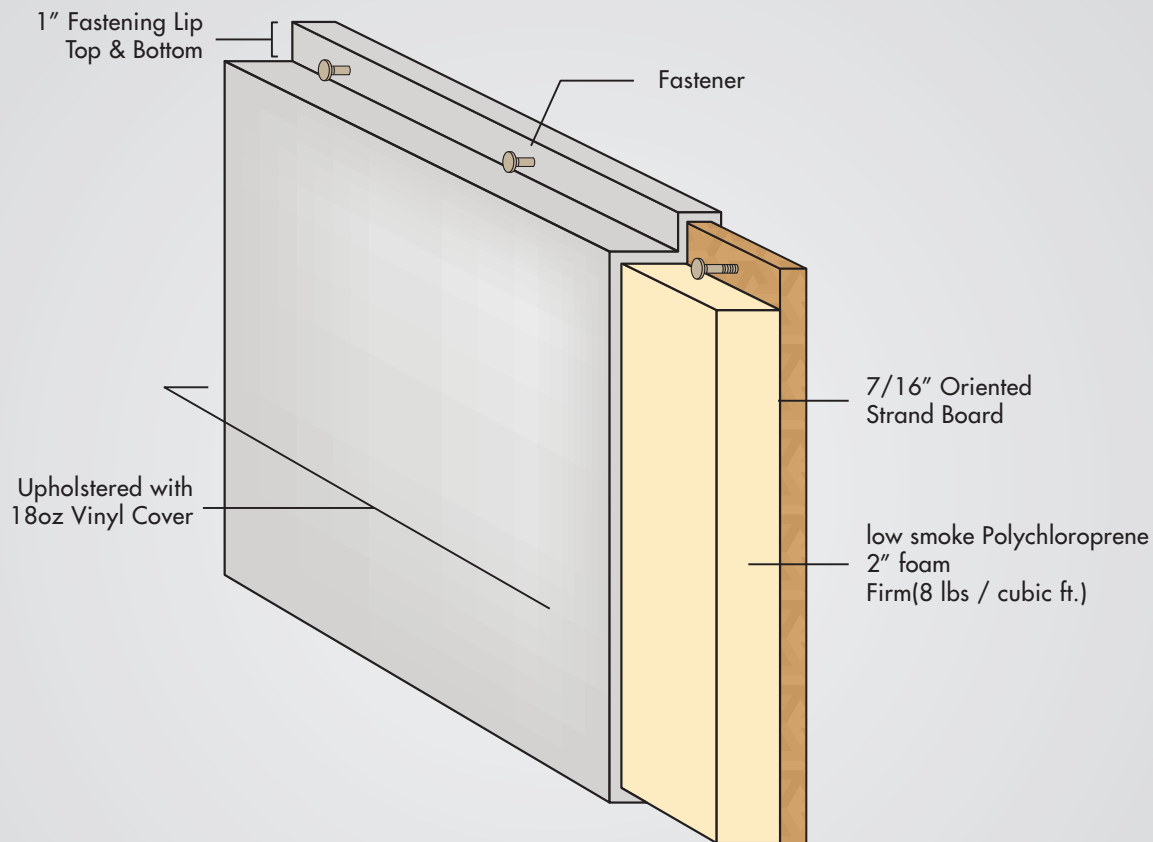

FOAM SPECIFICATIONS

- Wall pad backing is 7/16" oriented strand board
- 2" thick firm density CR Safeguard Foam 8 lbs. /cubic foot
- Surface burning Characteristics ASTM E84 Class A

COATED VINYL FABRIC (PVC)

SPECIAL FEATURES

- Overall weight 18 oz. per square yard
- Mildew and rot resistant
- California Bill 1108 compliant meeting less than 0.1% phthalates
- Lead free test ASTM 1613
- FR to NFPA 701 USA/CPAI 84 Section (2 second extinguish)
- Fire Retardant to CAN/ULCS 109
- Fire Retardant to ASTM E84 Class A

WALL PAD TESTED AS ASSEMBLY

Vinyl, foam, OSB – CAN/ULC- S102 PASS

COATED VINYL FABRIC (PVC)

AVAILABLE COLOURS

Cobalt Royal Blue, Royal Blue 2, Navy Blue, Forest Green, Kelly Green, Red, Burgundy, Purple, Pink, Yellow, Orange, White, Grey, Tan, Brown, Black